

**ARTICLE II
DEFINITIONS**

**CHAPTER 210
Definitions**

210.1 Interpretation of terms and words.

210.2 Definitions.

Sec. 210.1 INTERPRETATION OF TERMS AND WORDS.

For the purpose of this resolution, certain terms and words used herein shall be interpreted as follows:

- A. Words used in the present tense shall include the future tense, the plural number shall include the singular, and the singular number shall include the plural, unless specifically stated otherwise;
- B. The word “shall” is mandatory and not directory requirement, the word “may” is a permissive requirement, and the word “should” is a preferred requirement;
- C. The word “used” shall include the words “arranged”, “designed”, “constructed”, “altered”, “converted”, or “intended to be used”;
- D. The word “person” shall mean, in addition to an individual, a firm, corporation, association, organization, partnership, trust or any legal entity which may own and/or use land or buildings;
- E. The word “lot” shall include the words “plot” or “parcel”; and
- F. When the number of days is specified, days shall mean calendar days unless specifically stated otherwise.

Sec. 210.2 DEFINITIONS.

- A. Words used in this resolution are used in their ordinary English usage.
- B. For the purpose of this resolution the following terms, whenever used in this resolution, shall have the meaning herein indicated:

1. **ACCESS DRIVE:** A paved strip, which provides a vehicular connection between off-street parking spaces and a street.
2. **ACCESSORY BUILDING:** A subordinate building detached from, but located on the same lot as, the principal or main building, the use of which is incidental and accessory to that of the main building or use and which is constructed subsequent to construction of the principal building or establishment of the main use of land.
3. **ACCESSORY LIVING QUARTERS:** Living quarters within a single-family dwelling unit with no separate exterior entrance or if detached, in a separate accessory building. Such quarters shall have no kitchen facilities. Accessory living quarters shall be considered an accessory use.
4. **ACCESSORY USE:** A use that is on the same lot as and serves a purpose customarily incidental and subordinate to the principal use of a building or land and is established subsequent to the principal use.
5. **ADULT DAY CARE FACILITY:** A day care center that during any part of the normal business day provides supervised educational, recreational and social activities to elderly and/or handicapped adults, but not including persons suffering from acute or chronic alcoholism or other drug dependency and persons who regularly require restraint. See also “Day Care Center”.
6. **ADULT FAMILY HOME:** A residence licensed according to Chapter 3722 of the Ohio Revised Code to provide accommodations to not more than 5 unrelated adults and which provides supervision and personal services to at least 3 of those adults, where the adults live as a single housekeeping unit and the residence serves as the adults’ sole, bona fide permanent residence, but which does not provide nursing care or include residents who require “skilled nursing care” or “intermediate nursing care” and shall not include “homes” and “rest homes” as defined in ORC Chapter 3721.
7. **AGRICULTURE:** As used in Section 519.02 to 519.25 of the Ohio Revised Code, “agriculture” includes farming, ranching, aquaculture, apiculture, horticulture, viticulture, animal husbandry, including, but not limited to, the care and raising of livestock, equine, and fur-bearing animals; poultry husbandry and the production of poultry and poultry products, dairy production, the production of field crops, tobacco, fruits, vegetables, nursery stock, ornamental shrubs, ornamental trees, flowers, sod, or

mushrooms, timber, pasturage, any combination of the foregoing; the processing, drying, storage, and marketing of agricultural products when those activities are conducted in conjunction with, but are secondary to, such husbandry or production.

8. **ARCHITECTURAL FEATURE:** Any construction attending to, but not an integral part of a sign, building or structure and which may consist of landscaping or building or structural forms complementing the site in general. (Effective 10/22/09)
9. **ASSEMBLY HALL:** A building or establishment where members of a local chapter of an association or a fraternal, cultural, or religious organization hold their meetings and may engage in providing catering and entertainment for a fee.
10. **ASSOCIATION:** A legal entity operating under recorded land agreements or contracts through which each unit owner in a development is a member and each dwelling unit is subject to charges for a proportionate share of the expenses of the organization's activities such as maintaining the restricted open space, private streets and other common areas, and providing services needed for the development. An association can take the form of a homeowners' association, community association, condominium association or other similar entity.
11. **AUTOMOBILE DEALERSHIP:** Any business establishment that sells or leases new and used automobiles, light trucks [one (1) ton or less], vans, trailers, recreational vehicles, boats, or motorcycles as its primary use. An automobile dealership may maintain an inventory of the vehicles for sale or lease and may provide on-site facilities for the repair and service of the vehicles sold or leased by the dealership. (Effective October 12, 2006)
12. **AUTOMOTIVE SERVICE STATION:** A building or portion of a building where the retail sales of lubricants and motor vehicle accessories, the routine maintenance and service of vehicles, and repairs to vehicles are conducted, but in which the painting of cars, body and fender work or other major repairs described under Vehicle Repair Garage shall not be permitted.
13. **BASEMENT:** A space having one-half (1/2) or more of its floor to ceiling height below grade and with a floor to ceiling height of at least 6 ½ feet.
14. **BILLBOARD:** See "Outdoor Advertising Sign"

- 15. **BLOCK FRONT:** All the property on one (1) side of a street between two (2) intersecting streets (crossing or terminating) measured along the line of the street or, if the street is dead ended, all the property abutting on one (1) side between an intersecting street and the dead end of a street.
- 16. **BOARD:** The Board of Zoning Appeals.
- 17. **BUFFER:** A combination of physical space and vertical elements, such as plants, berms, fences, or walls, the purpose of which is to separate and screen different land uses from each other.
- 18. **BUILDING:** Any structure having a roof supported by columns or by walls and intended for the shelter, housing or enclosure of persons, animals or chattel. See also “Structure”.
- 19. **BUILDING, ACCESSORY:** See “Accessory Building”.
- 20. **BUILDING FRONTAGE:** The building wall which faces the front lot line of a principal building or building wall that contains the main entrance to the uses therein. (Effective 10/22/09)
- 21. **BUILDING, HEIGHT OF:** The vertical distance from the finished grade to the highest point of the coping of a flat roof or to the deck line of a mansard roof, or the mean height level between eaves and ridge line of gable, hip or gambrel roofs.

Figure 1.
Illustration for Determining Building Height.

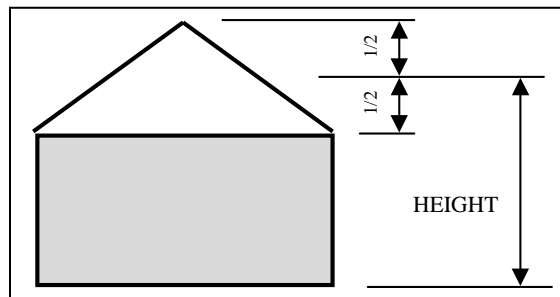

- 22. **BUILDING LINE:** An imaginary extension of the front building wall parallel to the street right-of-way line defining the limits of the front yard.
- 23. **BUILDING PERMIT:** A permit issued by the Medina County Building Department before construction, substantial rehabilitation or internal modifications can legally take place.

24. **BUILDING, PRINCIPAL:** A building on a lot used to accommodate a principal use to which the lot or parcel is devoted. (Revised 5/28/09)
25. **BUILDING UNIT:** The portion of a building that is owned or leased by a single tenant in a multi-tenant building. (Effective 10/22/09)
26. **CARPORT:** An accessory building that is not completely enclosed by walls or doors that serves as a covered automobile parking space. A carport shall be subject to all the provisions prescribed in these regulations for a private garage.
27. **CAR WASH:** A building or enclosed area that provides facilities for washing and cleaning motor vehicles, which may use production line methods with a chain conveyor, blower, and steam cleaning and/or high pressure devices and/or which may employ hand labor for the washing and/or waxing of automobiles.
28. **CENTRALIZED SEWER SYSTEM:** A system where individual lots are connected to a common sewerage system whether publicly or privately owned and operated.
29. **CENTRALIZED WATER SYSTEM:** A system where individual lots are connected to a common water distribution system whether publicly or privately owned and operated.
30. **CHILD DAY CARE:** Administering to the needs of infants, toddlers, pre-school children, and school children outside of school hours by persons other than their parents or guardians, custodians, or relatives by blood, marriage, or adoption for any part of the 24 hour day in a place or residence other than a child's own home. See also "Day Care Center".
31. **CLINIC, MEDICAL:** A building used for the care, diagnosis, and treatment of sick, ailing, infirm or injured human patients by a group of physicians or dentists practicing medicine together, but which is not used to lodge patients overnight. Such clinics may include ambulatory or emergency care centers.
32. **CLINIC, VETERINARY:** A place where animals are given medical or surgical treatment and the boarding of animals occurs only as necessary for the purpose of medical treatment.
33. **CLUSTER SINGLE-FAMILY:** See Dwelling, Detached Cluster Single Family.

34. **CO-LOCATION:** The use of a wireless telecommunications facility by more than one wireless communications provider. (Effective 5/28/09)
35. **COMMISSION.** The Montville Township Zoning Commission.
36. **COMMON AREA:** Any land area, and associated facilities, within a development that is held in common ownership through a Homeowners' Association, Community Association or other legal entity, or which is held by the individual members of a Condominium.
37. **COMMON DRIVE:** A private way that provides vehicular access to at least two but not more than three dwelling units. (Effective June 22, 2006)
38. **COMMUNICATION DEVICE:** Communication devices are defined as radio receivers/transmitters, television receivers/transmitters, microwave receivers/transmitters, and similar devices.
39. **COMMUNICATION DEVICE ANTENNA:** Any system of wires, poles, rods, reflecting discs, or similar devices used for the transmission or reception of electromagnetic waves, which system is external to or attached to the exterior of any building.
40. **COMPREHENSIVE PLAN/DEVELOPMENT PLAN:** The long-range plan for the development of the Township as officially adopted and amended by the Zoning Commission and Township Trustees. (Effective June 22, 2006)
41. **CONDITIONAL ZONING CERTIFICATE:** A permit issued by the Zoning Inspector upon approval by the Board of Zoning Appeals to allow a conditional use to be established within the district on a specific parcel. See also "Use, Conditional".
42. **CONGREGATE CARE FACILITY:** A residential facility that provides for the needs of individuals who are elderly or handicapped. The facility shall consist of residential dwelling units designed specifically for the elderly or handicapped, and have common social, recreational, dining and food preparation facilities, and may include skilled nursing care. See also "Homes for Handicapped Persons, Family and Group".
43. **DAY CARE CENTER:** Any place other than a family day care home in which day care is provided for either adults or children. See also "Adult Day Care Facility" and "Child Day Care".

44. DENSITY: A unit of measure expressing the number of dwelling units permitted per acre of land.
45. DISH ANTENNA: A device that receives communications or other signals from orbiting satellites and other extraterrestrial sources for home audio-video viewing, and which includes a low noise amplifier (LNA) which is situated at the focal point of the receiving component to magnify and transfer signals into the interior of the building.
46. DRIVE-THRU FACILITY: Any portion of a building or structure from which business is transacted, or is capable of being transacted, directly with customers while said customers remain in their motor vehicle during such business transactions. The term "drive-thru" shall also include "drive-up" and "drive-in" but shall not include "Car Wash", "Gasoline Station", and "Automobile Service Station".
47. DRIVEWAY, PRIVATE RESIDENCE: A path on a residential lot that extends from the street pavement for vehicular access to and from such street. See also Figure 6 at end of Chapter for driveway details.
48. DRY HYDRANT: A non-pressurized pipe system permanently installed in existing lakes, ponds and streams that provides a suction supply of water to a fire department tank truck.
49. DWELLING: Any building or portion thereof, containing one or more dwelling units and which is designed or used primarily for residence purposes, including attached and detached single-family dwellings as defined herein. (Revised 9/10/09)
50. DWELLING, ATTACHED SINGLE FAMILY: A dwelling consisting of two (2) or more dwelling units located side by side, not one above another, having common or adjoining walls and designed so that every dwelling unit has a private outside entrance at ground level.
51. DWELLING, DETACHED CLUSTER SINGLE FAMILY: A dwelling consisting of a single dwelling unit only, which shall not have common walls with other such dwellings but is grouped with other dwelling units on a site in an arrangement. The dwelling shall comply with the spacing requirements set forth for such units in the applicable planned residential development or planned neighborhood development regulations. (Revised 9/10/09)

- 52. **DWELLING, DETACHED SINGLE FAMILY:** A dwelling consisting of a single dwelling unit only, separated from other dwelling units by open space from ground to sky.
- 53. **DWELLING, STANDARD DETACHED SINGLE-FAMILY:** A building designed for, or used exclusively for, residence purposes by one family situated on an individual lot having a front, side, and rear yard. See also Figure 2.

Standard Detached Single-Family Dwellings.

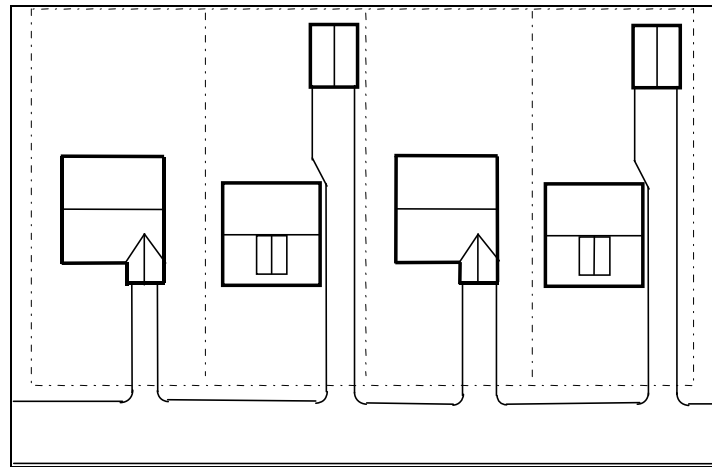

- 54. **DWELLING UNIT:** A group of rooms comprising living, dining, sleeping rooms, storage closets, as well as space and equipment for cooking, bathing and toilet facilities, for use by one (1) family.
- 55. **EASEMENT:** A grant by a property owner for the specific use of land by the general public, a corporation, or another person.
- 56. **EXCAVATION:** The removal, stripping or disturbance of soil, earth, sand, rock, gravel or other similar substances from the ground, including the clearing of trees.
- 57. **ESSENTIAL SERVICES:** Services and utilities needed for the health, safety, and general welfare of the community, such as underground, surface or overhead gas, electrical, steam or water transmission or distribution systems, collection, telephone, supply or disposal systems, including poles, wires, mains, drains, sewers, pipes, conduit cables, fire alarm boxes, police call boxes, traffic signals, hydrants, and other similar equipment and accessories in

connection therewith, but not including buildings, reasonably necessary for the furnishing of an adequate level of service for the area in which the service is located.

- 58. **FAÇADE:** The exterior walls of a building exposed to public view or that wall viewed by persons not within the building. (Effective 6/22/06)

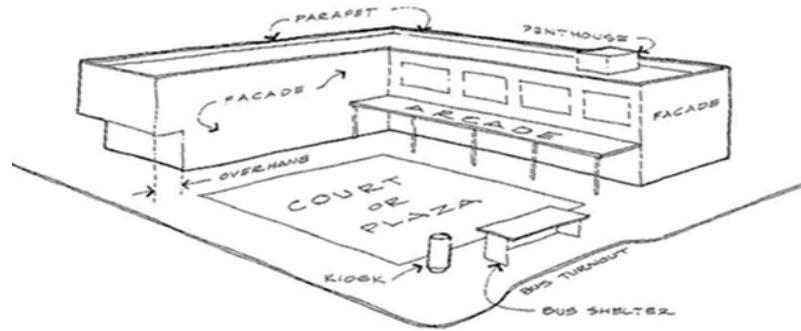

- 59. **FAMILY:** One individual or any number of individuals living as a single housekeeping unit, but not including groups occupying a hotel or motel as herein defined.
- 60. **FAMILY DAY CARE HOME, TYPE B:** A permanent residence of the provider in which child day care or child day care services are provided for one to six children at one time and in which no more than three children may be under two years of age at one time. In counting children for the purposes of this division, any children under six (6) years of age who are related to the provider and who are on the premises of the type B home shall be counted. "Type B family day care home" does not include a residence in which the needs of children are administered to, if all of the children whose needs are being administered to are siblings of the same immediate family and the residence is the home of the siblings, nor does it include any child day camp.
- 61. **FAMILY HOME FOR HANDICAPPED PERSONS:** A licensed residential facility that provides room and board, personal care, habilitative services, and supervision in a family setting for up to eight (8) handicapped persons. (See HANDICAPPED.) The term "family home for handicapped persons" does not include "halfway house" or other housing facilities serving as an alternative to incarceration, "nursing home", "rest home", "boarding house", "rooming house", "lodging house", "residential treatment home/center", "special care home" or any other such similar building or use of a building.

- 62. **FEDERAL EMERGENCY MANAGEMENT AGENCY (FEMA):** The agency with overall responsibility for administering the National Flood Insurance Program. (Effective 5/28/09)
- 63. **FENCE:** Any structure composed of wood, iron, steel, masonry, stone or other material and erected in such a manner and in such location as to enclose, secure, partially enclose or secure, provide privacy, decorate, define or enhance all or any part of any premises.
- 64. **FLEET VEHICLES:** Trucks, vans, and other vehicles, including motorized equipment, which are used as part of the operation of a principal use, but not including privately owned customer or employee vehicles.
- 65. **FLOODPLAIN, ONE HUNDRED YEAR:** Any land susceptible to being inundated by water from a base flood. The base flood is the flood that has a 1 percent (1%) or greater chance of being equaled or exceeded in any given year. The one hundred (100) year floodplain shall be identified by the Federal Emergency Management Agency maps of Montville Township. (Effective 5/28/09)
- 66. **FLOODWAY:** The channel of a river or other watercourse and the adjacent land areas within the floodplain that have been reserved in order to pass the 100-year flood discharge. A floodway is typically determined through hydraulic and hydrologic engineering analysis such that the cumulative increase in the flood elevation is no more than a designed height. (Effective August 9, 2007)

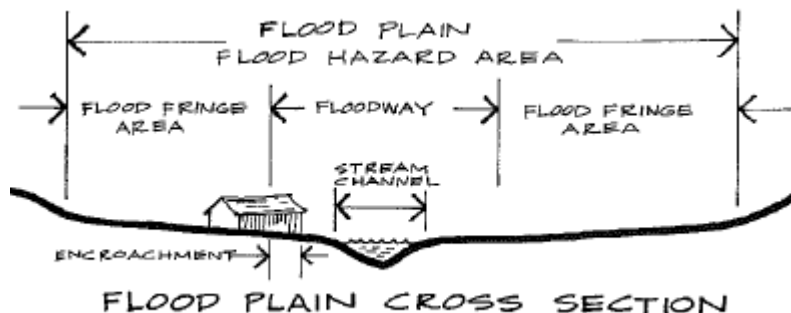

- 67. **FLOOR AREA, DWELLING UNIT:** The sum of the gross horizontal area of a dwelling unit measured from the exterior faces of exterior walls of the dwelling unit or from the center line of

common walls separating two dwelling units. It shall not include basements, attached garages, attics, terraces, breezeways, open porches, and covered steps.

- 68. FLOOR AREA, GROSS: The sum of the gross horizontal areas of all floors of a building, measured from the exterior faces of exterior walls or from the centerline of common walls separating two (2) or more units of a building. (Revised June 21, 2007)
- 69. FLOOR AREA, NET: The total of all gross floor area excluding: all floors below the first or ground floor; interior vehicular parking or loading; elevator and stair bulkheads; equipment rooms; attic space; terraces; breezeways; open porches; uncovered steps; and other areas not intended to be used by the public. However, if the basement is used for business or commercial purposes, human habitation and/or service to the public, it shall be counted as gross floor area only in computing off-street parking requirements. (Effective June 21, 2007)
- 70. FRONTAGE: See Lot Frontage.
- 71. FUNERAL HOME: A building or part thereof used for human funeral services. Such building may contain space and facilities for: (a) embalming and the performance of other services used in preparation of the dead for burial including the performance of autopsies and other surgical procedures; (b) the storage of caskets, funeral urns, and other related funeral supplies; and (c) the storage of funeral vehicles, but shall not include facilities for cremation. Where a funeral home is permitted, a funeral chapel shall also be permitted. (Revised 5/28/09)
- 72. GARAGE, PRIVATE: An accessory building or an accessory portion of the principal building, enclosed on all sides and designed or used for the shelter or storage of passenger vehicles and located on the same lot as the dwelling to which it is accessory.
- 73. GASOLINE STATION: An establishment where liquids used as motor fuels are stored and dispersed into the fuel tanks of motor vehicles by an attendant or by persons other than the station attendant and may include facilities available for the sale of other retail products.
- 74. GRADE, FINISHED: The average level of the finished surface of ground adjacent to the exterior walls of the building after final grading and normal settlement.

- 75. **GRADE, NATURAL:** The elevation of the undisturbed natural surface of the ground prior to any excavation or fill.
- 76. **GROSS AREA:** Land area, measured on the horizontal plane and including land occupied by all natural and manmade features of the landscape.
- 77. **GROUP HOME FOR HANDICAPPED PERSONS:** A licensed residential facility that provides room and board, personal care, habilitative services, and supervision in a family setting for at least nine (9) handicapped persons. (See HANDICAPPED.) The term "group home for handicapped persons" does not include "halfway house" or other housing facilities serving as an alternative to incarceration, "nursing home", "rest home", "boarding house", "rooming house", "lodging house", "residential treatment home/center", "special care home" or any other such similar building or use of a building.
- 78. **HANDICAPPED:** A physical or mental impairment, as defined in 42 U.S.C. 3602 (h), that substantially limits one or more of such person's major life activities. However, "handicapped" shall not include current illegal use of or addiction to a controlled substance, nor shall it include any person whose residency in a home would constitute a direct threat to the health and safety of other individuals.
- 79. **HARDWARE:** Manufactured articles such as locks, fittings, cutlery, tools, utensils or parts of machines that are made of metal, but excluding firearms and heavy military equipment.
- 80. **HAZARDOUS SUBSTANCES:** Any substance or material that, by reason of its toxic, caustic, corrosive, abrasive or otherwise injurious properties, may be detrimental or deleterious to the health of any person handling or otherwise coming in contact with such material or substance.
- 81. **HOME FOR HANDICAPPED PERSONS, FAMILY:** See Family Home for Handicapped Persons.
- 82. **HOME FOR HANDICAPPED PERSONS, GROUP:** See Group Home for Handicapped Persons.
- 83. **HOME OCCUPATION:** Any use or profession conducted entirely within a dwelling and carried on only by the inhabitants thereof, which use is clearly incidental and secondary to the use of the dwelling for dwelling purposes and does not change the character thereof.

84. HOSPITAL: An establishment that provides, through a medical staff, permanent facilities that include in-patient beds, medical services, and continuous nursing services, diagnosis and treatment, both surgical and non-surgical, for human patients who have any of a variety of acute medical conditions.
85. HOTEL/MOTEL: A commercial building in which lodging is provided and offered to the public for compensation on a daily rate.
86. IMPERVIOUS COVER: Any paved, hardened or structural surface regardless of its composition including, but not limited to, buildings, roads, driveways, parking lots, loading/unloading spaces, decks, patios, and swimming pools. (Effective 5/28/09)
87. INDOOR COMMERCIAL RECREATION: An indoor facility for any number of uses such as game courts, exercise equipment, exercise and/or dance floor area, pools, locker rooms, spa, whirlpool or hot tub, and which may include an accessory retail shop for the sale of related equipment.
88. INOPERABLE MOTOR VEHICLE: Any motor propelled vehicle or accessory to same, which is, or is in the process of being, wrecked, or dismantled such that the engine, wheels, or other parts have been removed or on which the engine, wheels or other parts have been altered, damaged or otherwise so treated that the vehicle is incapable of being driven under its own motor power.
89. INSTITUTION: A building occupied by a non-profit corporation or a non-profit establishment for public use.
90. INTERMITTENT STREAM: A natural channel that may have some water in pools but where surface flows are non-existent or interstitial (flowing through sand and gravel in stream beds) for periods of one week or more during typical summer months.
91. JUNK: Bones, litter and manufactured goods including, but not limited to scrap iron, scrap tin, scrap glass, scrap brass, scrap copper, scrap lead or scrap zinc and all other scrap metals and their alloys, rags, used cloth, used rubber, used rope, used tinfoil, used bottles, old and used machinery, used tools, used appliances, used fixtures, used utensils, used building materials, used boxes or crates, used pipe or pipe fittings, and used tires that are so worn, deteriorated or obsolete as to make them unusable in their existing condition, but are subject to being dismantled or recycled.
92. JUNK YARD: The use of more than 25 square feet of any land, building or structure, whether for private and/or commercial purposes, where waste, discarded or salvaged materials such as

scrap metals used building materials, used lumber, used glass, discarded motor vehicles, paper, rags, rubber, cordage, barrels, etc. are sold, stored, bought, exchanged, baled, packed, sorted, disassembled, dismantled or handled.

93. LAND DEVELOPMENT ACTIVITY: Any change to the surface area of a lot including, but not limited to, clearing, grubbing, stripping, removing vegetation, dredging, grading, excavating, cutting and filling, constructing buildings or structures, paving, and any other installation of impervious cover. (Effective 5/28/09)
94. LANDSCAPED AREA: An area that is permanently devoted to and maintained for the growing of trees, shrubs, grass or other plant material, and may include non-living durable materials such as rocks, decorative walls and fences, but shall exclude paving.
95. LATTICE TOWER: A support structure constructed of vertical metal struts and cross braces forming a triangular or square structure, which tapers from the foundation to the top. (Effective 5/28/09)
96. LIBRARY: A facility operated by a governmental or non-profit entity open to the general public in which literary and artistic materials, such as books, periodicals, newspapers, pamphlets, prints, records, compact discs, videos, films, Internet access, and tapes, are made available for use, reading, review, and lending, but not for general sale.
97. LOADING SPACE: An off-street space or berth on the same lot with a building, or contiguous to a group of buildings, for the temporary parking of a commercial vehicle while loading or unloading merchandise or materials, and which abuts upon a street, alley or other appropriate means of access.
98. LOT: A designated parcel, tract, or area of land established by plat, subdivision, or as otherwise permitted by law, to be separately owned, used, developed, or built upon. (Effective June 22, 2006)
99. LOT AREA: The computed horizontal area contained within the lot lines, exclusive of any portion of the right-of-way of any public street.
100. LOT, DE MINIMIS: A lot that contains the entire building foundation of a single-family detached cluster dwelling, which may contain nominal additional land surrounding said building

foundation, and which is established and used in conjunction with surrounding areas of common open space.

- 101. LOT FRONTAGE: That portion of a lot extending along the street right-of-way.
- 102. LOT LINES: The property lines defining the limits of a lot. See also Figure 3.
 - a) LOT LINE, FRONT: The lot line separating a lot from the street right-of-way on which the lot fronts.
 - b) LOT LINE, REAR: The lot line opposite and most distant from the front lot line; or in the case of triangular or otherwise irregularly shaped lots, a line 10 feet in length entirely within the lot, parallel to and at a maximum distance from the front lot line. On corner lots, the rear lot line shall be considered as parallel to the street upon which the lot has its least dimension.
 - c) LOT LINE, SIDE: Any lot line other than a front or rear lot line.

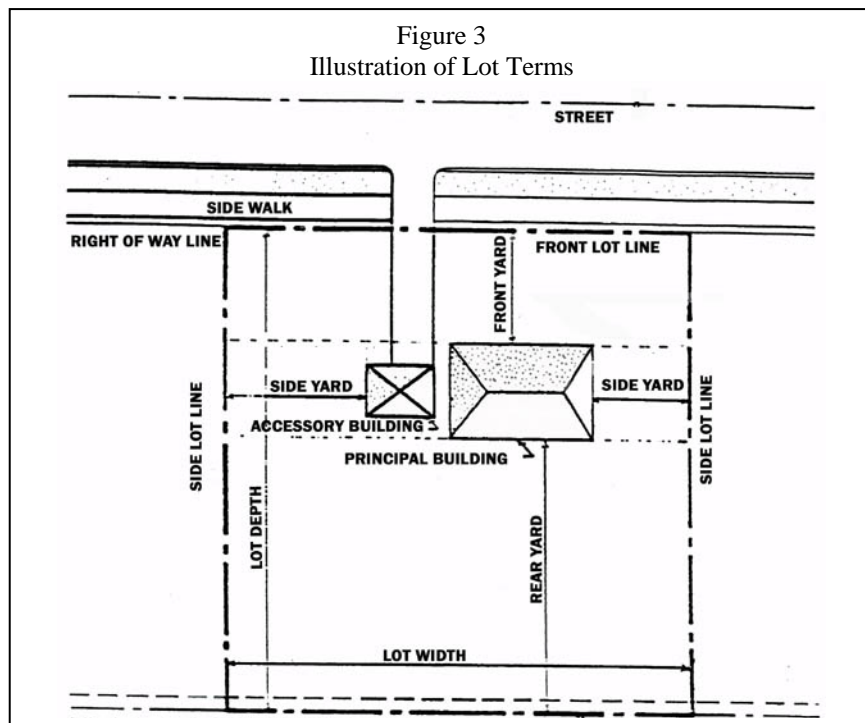

103. LOT TYPES: Terminology used in this resolution with reference to corner lots, interior lots, double frontage lots and through lots is as follows. See also Figure 4 for an illustration of lot types.

a) LOT, CORNER: A lot at the junction of and abutting upon two (2) intersecting streets.

Figure 4.
Illustration of Lot Types.

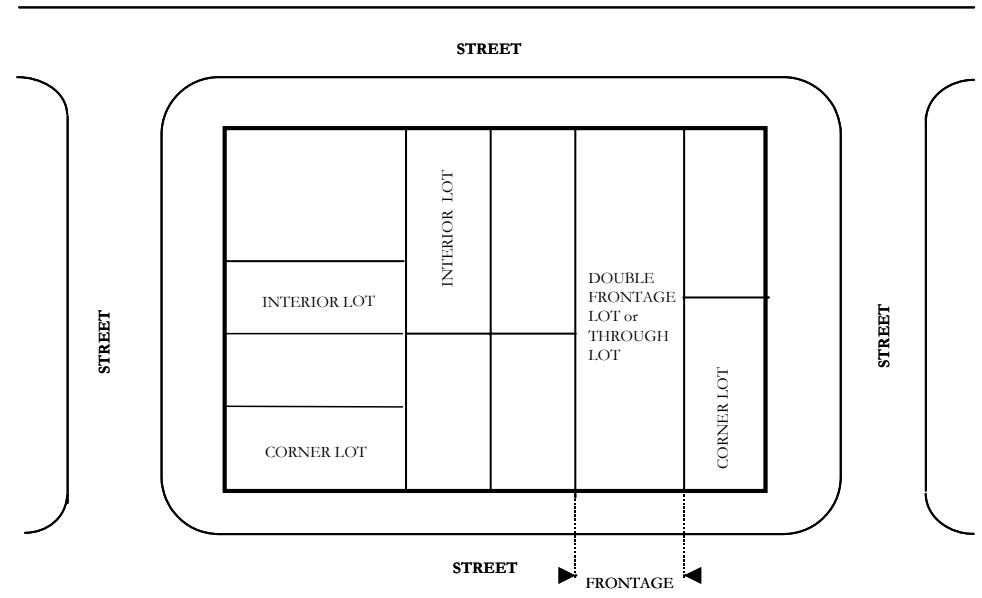

b) LOT, DOUBLE FRONTAGE: A lot having a frontage on two (2) non-intersecting streets, as distinguished from a corner lot.

c) LOT, INTERIOR: A lot other than a corner lot with frontage on only one (1) street.

104. LOT OF RECORD: A lot which has been recorded in the office of the Recorder of Medina County.

105. **LOT WIDTH:** The horizontal distance between the side lot lines measured at the front setback line and perpendicular to or as nearly perpendicular to the side lot lines as possible. See also Figure 5.

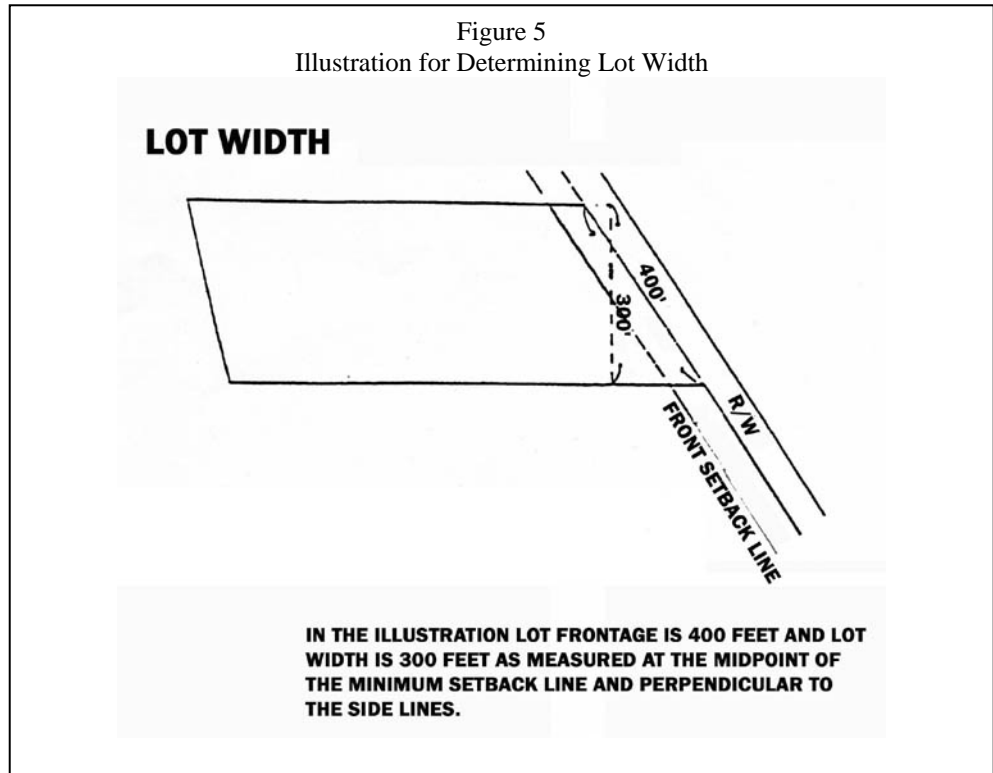

106. **MANUFACTURED HOME:** A dwelling unit fabricated at an off-site manufacturing facility for installation or assembly at the building site, bearing a label certifying that it is built in compliance with the Federal Manufactured Housing Construction and Safety Standards Act of 1974 (42 USC 5401 et. seq.).
107. **MINIMUM SETBACK LINE.** See Setback Line.
108. **MODEL HOME:** A dwelling unit used initially for display purposes which typifies the type of units that will be constructed in the subdivision and which will not be permanently occupied during its use as a model.
109. **MONOPOLE:** A support structure constructed of a single, self-supporting hollow metal tube securely anchored to a foundation. (Effective 5/28/09)
110. **MOTEL:** See Hotel.

- 111. NONCONFORMITY: A lot, use of land, building, use of buildings, or use of buildings and land in combination lawfully existing at the time of enactment of this Zoning Resolution or its amendments, which do not conform to the regulations of the district or zone in which it is situated.
 - a) NONCONFORMING BUILDING OR STRUCTURE: A building or structure existing when this Zoning Resolution or any amendment thereto became effective, which does not conform to the regulations governing buildings of the district in which it is located.
 - b) NONCONFORMING LOT: A lot lawfully existing on the effective date of this Zoning Resolution or any amendment thereto, which does not conform to the lot area, width or frontage requirements of the district in which it is located.
 - c) NONCONFORMING SITE CONDITION: Any structure lawfully existing on the effective date of this Zoning Resolution or any amendment thereto, which does not conform to the yard regulations, parking requirements, sign regulations, landscaping or screening requirements or other development standards of the district in which it is situated.
 - d) NONCONFORMING USE: Any building or land lawfully occupied by a use on the effective date of this Zoning Resolution or any amendment thereto, which does not conform to the use regulations of the district in which it is situated.
- 112. OHIO ENVIRONMENTAL PROTECTION AGENCY: The State government agency referred to herein as the Ohio EPA. (Effective 5/28/09)
- 113. OPEN SPACE: The portion of a lot not covered by a building or parking and/or loading area and which is open to the sky. It may include walkways, landscaping, fences, recreation areas and objects not defined under buildings or structures
- 114. OPEN SPACE, USEABLE: Open space used for active or passive recreation. Useable open space may include common buildings such as shelters, pavilions, or recreational structures that are centrally located and accessible to the occupants of the building or buildings. (Effective October 12, 2006)
- 115. ORDINARY HIGH WATER MARK: The point of the bank or shore to which the presence and action of surface water is so continuous as to leave a district marked by erosion, destruction, or

prevention of woody terrestrial vegetation, predominance of aquatic vegetation, or other easily recognized characteristics. The ordinary high water mark defines the bed of a watercourse. (Revised 5/28/09)

- 116. **OUTDOOR COMMERCIAL RECREATION:** A facility for recreational uses that are conducted primarily outdoors as opposed to an indoor recreation facility.
- 117. **OUTDOOR DISPLAY:** The placing of merchandise in an outdoor area that is open to the general public when the merchandise on display is removed from its shipping packaging and is representative of merchandise that is available for purchase inside the building and/or is available for purchase by the general public directly from the display area.
- 118. **OUTDOOR STORAGE:** The keeping, in an area outside of a building, of any goods, material, merchandise, or vehicles in the same place for more than 24 hours, which does not otherwise meet the definition of outdoor display.
- 119. **PARKING LOT:** An outdoor paved area made up of marked parking spaces where motor vehicles may be stored for the purposes of temporary off-street parking. Also known as a parking area.
- 120. **PARKING SPACE:** An off-street space defined by painted lines, raised curbs or otherwise designated, which is used for the temporary parking of a motor vehicle that may be stored for a period longer than that required to load or unload persons or goods.
- 121. **PERENNIAL STREAM:** A natural channel that contains water throughout the year, except possibly during periods of extreme drought.
- 122. **PERIMETER DIKE:** A ridge of compacted soil located along the perimeter of a site and around any storage tanks or pits.
- 123. **PERFORMANCE STANDARD:** A criterion established to control enclosure, dust, smoke, fire and explosive hazards, lighting, glare and heat, noise, odor, toxic and noxious matter, vibrations and other conditions created by or inherent in uses of land or buildings.
- 124. **PLACE OF WORSHIP:** A building, structure, or other indoor or outdoor facility used for public worship. The word "place of worship" includes the words "church," "chapel," "synagogue,"

- “mosque,” (Effective June 22, 2006) and "temple" and their uses and activities that are customarily related.
125. PLAN, DEVELOPMENT: Drawing(s) and map(s) illustrating the proposed design, layout, and other features for the development of one or more lots.
 126. PLAN, PRELIMINARY DEVELOPMENT: Proposed drawings and maps including all of the required elements set forth in this Zoning Resolution. (Effective June 22, 2006)
 127. PLAN, FINAL DEVELOPMENT: Final drawings and maps including all of the required elements set forth in this Zoning Resolution. (Effective June 22, 2006)
 128. PLANNED NEIGHBORHOOD DEVELOPMENT: A planned, integrated residential development approved by the Township Trustees as set forth in this Zoning Resolution. (Effective June 22, 2006)
 129. PLANNED RESIDENTIAL DEVELOPMENT: A planned, integrated residential development where minimum lot size and dwelling type may be modified somewhat to achieve particular design objectives and the economical provision of open space and utilities while maintaining the same over-all density limitations of the district in which the planned residential development is located and complying with other pertinent requirements of this Resolution and site design requirements of the Zoning Commission in accordance with Chapter 414. (Effective June 22, 2006)
 130. PLAT: A map of a lot, tract or subdivision on which the lines of each element are shown by accurate distances and bearings.
 131. POND, IN-LINE: A permanent pool of water created by impounding a designated watercourse. (Effective 5/28/09)
 132. PROJECT BOUNDARY: The boundary defining the tract(s) of land that is included in a proposed development to meet the minimum required project area for a planned neighborhood development, planned commercial development, or planned residential development. The term “project boundary” shall also mean “development boundary.” (Revised 9/10/09)
 133. PUBLIC LANDS: Parks, playgrounds, trails, paths and other recreational areas and open spaces; scenic and historic sites, schools and other buildings and structures; and other places that are owned

by a public entity such as the federal, state or local government, and where the public is directly or indirectly invited to visit or permitted to congregate.

- 134. PUBLIC SAFETY FACILITY: A governmentally owned and operated facility established to provide police or fire safety services to the surrounding area.
- 135. PUBLIC SERVICE/MAINTENANCE FACILITY: A governmentally owned and operated facility that provides for the upkeep and maintenance of the community such as but not limited to a service garage, maintenance building, and salt dome.
- 136. PUBLIC UTILITY: Any person, firm, corporation, governmental agency or board that furnishes to the public, electricity, gas, steam, telephone, cable television, telegraphy, transportation, water or any other similar public utility according to the criteria established by Ohio case law.
- 137. RESEARCH OR TESTING LABORATORIES: A building or group of buildings for scientific research, investigation, testing or experimentation, but not facilities for the manufacture or sale of products, except as incidental to the main purpose of the laboratory.
- 138. RESTAURANT - COUNTER SERVICE: A retail service establishment whose principal business is the sale of foods, frozen desserts, or beverages in ready-to-consume individual servings, for consumption either within the restaurant building or for carry-out, and where customers are not served their food, frozen desserts, or beverages by a restaurant employee at the same table or counter where the items are consumed.
- 139. RESTAURANT - TABLE-SERVICE: A retail service establishment wherein the entire business activity, or substantially all of the business activity, consists of the sale of food and service to patrons seated at tables for consumption within the building.
- 140. RESTRICTED OPEN SPACE: The portion of the open space within a planned neighborhood or planned residential development that is of sufficient size and shape to meet the minimum zoning requirements, and on which further development is restricted according to the provisions of Sec. 412.5 or 414.7, depending on the type of development proposed. (Revised 9/10/09)
- 141. RETAIL ESTABLISHMENT: An establishment engaged in the selling of goods or merchandise to the general public for personal or household consumption, which is open to the general public during

regular business hours and which has display areas that are designed and laid out to attract the general public.

- 142. **RIGHT-OF-WAY:** A strip of land taken, dedicated, or otherwise recorded as an irrevocable right-of-passage for use as a public way. In addition to the roadway, it normally incorporates the curbs, lawn strips, sidewalks, water and sewer lines, lighting, and drainage facilities, and may include special features (required by the topography or treatment) such as grade separation, landscaped areas, viaducts, and bridges.
- 143. **RIGHT-OF-WAY LINE:** The line between a lot, tract, or parcel of land and a contiguous public street, and demarcating the public right-of-way. "Right-of-way line" also means "street line." Where the lot, tract or parcel of land has been conveyed to the center of the street, the street right-of-way line then becomes the demarcation line indicating land reserved for street purposes. Where the right-of-way line is not established the width of the right-of-way shall be assumed to be 60 feet.
- 144. **RIPARIAN AREA:** Naturally vegetated land adjacent to designated watercourses which, if appropriately sized, helps to stabilize streambanks, limit erosion, reduce flood flows and/or filter and settle out runoff pollutants or which perform other functions consistent with the purposes of this Zoning Resolution. (Revised 5/28/09)
- 145. **RIPARIAN SETBACK:** The real property adjacent to a designated watercourse located within the area defined by the criteria set forth in these regulations. (Revised 5/28/09)
- 146. **ROADSIDE STANDS:** A removable structure used or intended to be used solely by the owner or the tenant of the property on which it is located for the sale of seasonal agriculture products produced on the premises.
- 147. **ROOF:** The outside top covering of a building. (Effective June 22, 2006)
- 148. **ROOF, FLAT:** A roof that is not pitched and the surface of which is generally parallel to the ground (see illustration). (Effective June 22, 2006)
- 149. **ROOF, GABLE:** A ridged roof forming a gable at both ends of the building (see illustration). (Effective June 22, 2006)

- 150. ROOF, GAMBREL: A gabled roof with two slopes on each side, the lower steeper than the upper (see illustration). (Effective June 22, 2006)
- 151. ROOF, HIP: A roof with sloping ends and sides (see illustration). (Effective June 22, 2006)
- 152. ROOF, MANSARD: A roof with two slopes on each of four sides, the lower steeper than the upper (see illustration). (Effective June 22, 2006)
- 153. ROOF, SHED: A roof with one slope (see illustration). (Effective June 22, 2006)

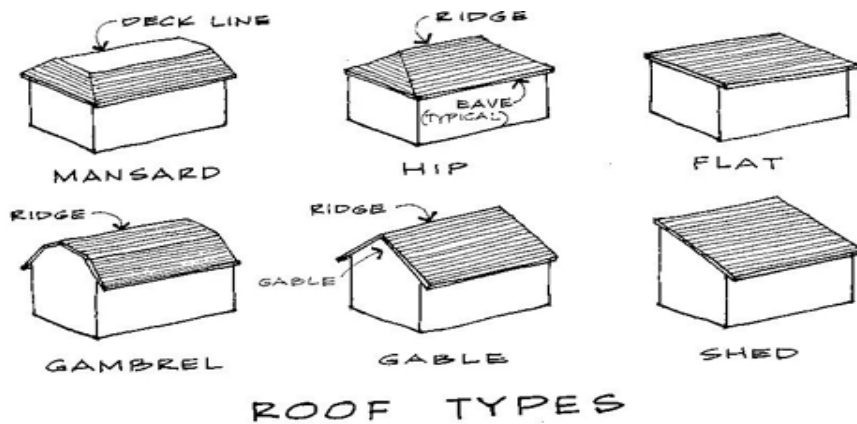

- 154. SCHOOL FACILITIES: Publicly or privately owned facilities providing full-time day instruction and training at the elementary, junior high and high school levels in accordance with the requirements of Chapter 3313 of the Ohio Revised Code; or publicly or privately owned facilities providing kindergarten or nursery school training and care which are operated by a board of education or an established religious organization.
- 155. SELF-SERVICE STORAGE FACILITY: A self-service facility comprised of individual storage units that are available for rent and/or individual ownership, and restricted to personal private access.
- 156. SEMI-PUBLIC USE: A non-profit entity including a church or other place of worship, institution for higher education, institutional meeting facility, public safety facility, public or private school, library, hospital, community center, and not-for-profit recreational facility.

157. **SETBACK:** The required minimum horizontal distance between a lot line and a structure as established by this Resolution. Where a major thoroughfare or collector street is designated on the Land Use and Thoroughfare Plan, the front setback shall be measured from the proposed right-of-way line.
158. **SETBACK LINE** (See also “Yard, Required”): A line established by this Zoning Resolution generally parallel with and measured from a lot line, defining the minimum distance a building, structure, parking area or outdoor storage area shall be located from said lot line, except as may be provided in this Zoning Resolution. The term "setback line" shall also include "required setback line" and “minimum setback line”.
159. **SHOPPING CENTER:** A group of commercial establishments; planned, constructed and managed as a total entity, with customer and employee parking provided on-site, provision for goods delivery separated from customer access, aesthetics considerations and protection from the elements and landscaping and signage in accordance with an approved plan. (Effective June 22, 2006)
160. **SIGN:** Any identification, description, illustration, object or device which is affixed to or integrated into a building or structure or land, or otherwise situated on a lot and which is intended to announce, direct or advertise by any means including letters, words, figures, designs, colors, symbols, fixtures, or images.
161. **SIGN, ADDRESS:** A sign indicating the address of a property to easily allow identification by safety services.
162. **SIGN, AWNING OR CANOPY SIGN:** Any sign that is painted on, part of or attached to an awning, canopy, or other fabric, plastic, or structural protection cover over a door, entrance, window, or outdoor service area.
163. **SIGN, BILLBOARD:** A sign that is supported from the ground or a structure other than a building that directs attention to a business, commodity, service or entertainment conducted, sold, or offered at a location other than the premises on which the sign is located. (Revised 5/28/09)
164. **SIGN, CANOPY:** SEE “SIGN, AWNING” (Effective 5/28/09)
165. **SIGN, CHANGEABLE COPY:** A ground sign or interstate pole sign such as a bulletin board or announcement board, where the messages or graphics are not permanently affixed to the structure,

framing, or background and may be periodically replaced or covered over manually or by electronic or mechanical devices.

- 166. SIGN, DIRECTIONAL: A permanent sign located on private property, at or near the public right-of-way, directing or guiding vehicles from the street onto private property.
- 167. SIGN, FLAG: Shall mean any sign of cloth or similar material, anchored along one side, displayed from a single pole, either freestanding or attached to a building.
- 168. SIGN, FLASHING: Any directly or indirectly illuminated sign that exhibits changing natural or artificial light or color effects by any means.
- 169. SIGN, GROUND: A sign that is placed upon, mounted in, or supported from the ground or a structure other than a building. (Revised 5/28/09)
- 170. SIGN, ILLUMINATED: A sign with an artificial light source incorporated internally or externally for the purpose of illuminating the sign.
- 171. SIGN, INTERSTATE POLE: A sign mounted on a pole or other similar support that is placed upon, mounted in, or supported from the ground and located within 660 feet of the Interstate 71 right-of-way. (Revised 5/28/09)
- 172. SIGN, NONCONFORMING: Shall mean any sign existing on or after the effective date of Montville Township Sign Regulations Chapter 510.2 which does not conform to said Regulations in its entirety.
- 173. SIGN, PROJECTING: A sign attached to a building or wall and which extends beyond the line of said building or wall in such a manner that the exposed face or faces of the sign are generally perpendicular to or at an angle to the plane of the wall of the building or structure to which said sign is attached, with its leading edge extending not more than 18 inches beyond the surface of such building or wall. (Revised 5/28/09)
- 174. SIGN, PUBLIC PURPOSE/SAFETY: A sign authorized by law erected by a public authority, utility, public service organization, or private industry upon the public right-of-way or on private property and which is intended to control traffic; direct, identify or inform the public; or provide needed public service.

- 175. SIGN, ROOF: Any sign painted on, attached to, or maintained upon or over the roof or parapet wall of any building, and having its principal support on the roof or walls of the building.
- 176. SIGN, TEMPORARY: Shall mean any sign, banner, flag, pennant, or other display of cloth, canvas, wallboard, board, plastic or other such material, designed to be displayed for a limited period of time.
- 177. SIGN, V: A ground sign containing two faces of approximately equal size, erected upon common or separate structures, positioned in a “V” shape. (Effective 5/28/09)
- 178. SIGN, WALL: A sign painted on, attached to, or erected against the outside wall of a building with the exposed face of the sign in a plane parallel to the plane of said wall, extending not more than 12 inches there from and which does not project above the roofline or beyond the corner of the building. (Revised 5/28/09)
- 179. SIGN, WINDOW: A sign that is applied or attached to a window or located inside a building within three (3) feet of a window so that the sign is visible and capable of being read from the outside of the building.
- 180. SOIL AND WATER CONSERVATION DISTRICT (SWCD): The Medina County, Ohio Soil and Water Conservation District, organized under Chapter 1515 of the Ohio Revised Code, including the Board of Supervisors and its designated employees. (Effective 5/28/09)
- 181. SOIL DISTURBING ACTIVITY: Clearing, grading, excavating, filling, or other alteration of the earth’s surface where natural or human made ground cover is destroyed and that may result in, or contribute to, erosion and sediment pollution. (Effective 5/28/09)
- 182. SPEC. HOME: A building or structure existing or proposed to be constructed for the purpose of being offered for immediate sale to the public, in contrast to a model home that is not offered sale immediately upon completion of construction.
- 183. STABLE, PRIVATE: A shelter for animals owned by the occupants of the dwelling to which it is an accessory use.
- 184. STORY: That portion of a building included between the surface of any floor and the surface of the next floor above it, or if there is no floor above it, then the space between the floor and the ceiling next above it.

185. **STREAM:** A body of water running or flowing on the earth's surface or a channel in which such flow occurs. Flow may be seasonally intermittent.
186. **STREAM BANK STABILIZATION:** Soil disturbing activities undertaken to control erosion along the banks of designated watercourses. Stream bank stabilization shall also include stream restoration that is defined as the process of converting an unstable, altered, or degraded stream corridor, including adjacent riparian area and flood prone areas, to its natural or referenced stable conditions, considering recent and future watershed conditions. Stream restoration also includes restoring the geomorphic dimension, pattern, and profile as well as biological and chemical integrity, including transport of water and sediment produced by the stream's watershed in order to achieve dynamic equilibrium. (Effective 5/28/09)
187. **STREET:** A way for vehicular traffic, publicly or privately owned, whether designated as a street, highway, thoroughfare, parkway, throughway, road, avenue, court, lane, alley, trail, terrace, boulevard or otherwise.
- a) **ALLEY:** A public thoroughfare that affords only a secondary means of access to a lot or abutting property.
 - b) **STREET, ARTERIAL:** A street primarily for through traffic usually on a continuous route between areas, across the county, and to and from expressways.
 - c) **STREET, COLLECTOR:** A street that primarily carries traffic from local to arterial streets, including the principal entrance and circulation routes within residential subdivisions.
 - d) **STREET, INTERIOR:** A street wholly within the boundaries of a development.
 - e) **STREET, LOCAL:** A street primarily for providing access to residential or other abutting property.
 - f) **STREET, PRIVATE:** An easement which provides vehicular access to residential or commercial structures or groups of structures and which will not be dedicated for public use.
 - g) **STREET, PUBLIC:** A public thoroughfare which has been dedicated to the public for public use or subject to public easements thereof, and which affords the principal means of access to abutting property.

- h) THOROUGHFARE. A street or alley.
- 188. STREET RIGHT-OF-WAY LINE: See “Right-of-Way Line”.
- 189. STRUCTURE: Anything constructed or erected, the use of which requires permanent or temporary location on the ground or attached to something having a permanent or temporary location on the ground, including, but not limited to buildings, signs, billboards, pergolas, roadside stands, fences, walls used as fences, decks, pools, sheds, or off-street parking facilities.
- 190. STRUCTURAL ALTERATIONS: Any change in the supporting members of a building, such as bearing walls or partitions, columns, beams or girders, or any increase in the area of cubical contents of the building.
- 191. SWIMMING POOL/SPA: An outdoor structure capable of containing in excess of two (2) feet of water at its deepest point or having more than 100 square feet of water surface.
 - a) SWIMMING POOL/SPA, PRIVATE: A swimming pool or spa located on a lot as an accessory use to a dwelling maintained and used solely by the owner or lessee thereof and his/her family and guests, without charge for admission and not operated for profit.
 - b) SWIMMING POOL, CLUB: A pool operated by a private club incorporated as a nonprofit organization to maintain and operate a swimming pool for the exclusive use of members generally limited to a geographic area.
 - c) SWIMMING POOL, COMMERCIAL: A pool operated for profit and open to the public upon payment of a fee.
- 192. TCF: Wireless telecommunications tower, antenna and/or facility. (Effective 5/28/09)
- 193. TELECOMMUNICATIONS: The technology that enables information to be exchanged through the transmission of voice, video or data signals by means of electrical or electromagnetic systems and includes the term “Personal Wireless Service.” (Effective 5/28/09)
- 194. TEMPORARY BUILDING OR STRUCTURE: A structure intended for a limited duration in which the construction or erection of such building or structure requires no permanent foundation.

195. TRAILER OR MOBILE HOME: Any vehicle or structure constructed in such a manner as to permit occupancy thereof as sleeping quarters or the conduct of any business, trade or occupation, or use as a selling or advertising device, or use for storage or conveyance for tools, equipment, or machinery and so designed that it is or may be mounted on wheels and used as a conveyance on highways and streets, propelled or drawn by its own or other motor powers.
196. TREES, DAMAGED OR DISEASED: Trees that have split trunks; broken tops; heart rot; insect or fungus problems that will lead to imminent death; undercut root systems that put the tree in imminent danger of falling; lean as a result of root failure that puts the tree in imminent danger of falling; or any other condition that puts the tree in imminent danger of being uprooted or falling into or along a watercourse or onto a building or structure. (Effective 5/28/09)
197. TRUSTEES: The Board of Trustees of Montville Township.
198. UPLANDS: Lands consisting of material unworked by water in recent geologic time and lying, in general, at a higher elevation than the alluvial plain or stream terrace. Land above the lowlands along rivers.
199. USE: The purpose for which a building or land is arranged, designed, intended, maintained or occupied. In the classification of uses, a “use” may be a use as commonly understood or the name of an occupation, business, activity or operation carried on, or intended to be carried on, in a building or on premises, or the name of a building, place or thing which name indicates the use or intended use.
- a) USE, ACCESSORY: See “Accessory Use”.
 - b) USE, CONDITIONAL: A use permitted in a district, other than a principal use permitted by right, which is allowed only under certain conditions as set forth in Chapter 450, and which requires a conditional zoning certificate and approval of the Board of Zoning Appeals in compliance with the regulations and procedures set forth in Chapter 730. See also “Conditional Zoning Certificate”.
 - c) USE, PERMITTED: A use that is authorized by the Montville Township Zoning Resolution as either a use permitted by right, a conditional use or an accessory use.

- d) **USE PERMITTED BY RIGHT:** A permitted use that is approved administratively when it complies with the standards and requirements set forth in the Zoning Resolution, the approval of which does not require a public hearing.
 - e) **USE, PRINCIPAL:** The primary or main use or activity of a building or lot.
- 200. **VEHICLE REPAIR GARAGE:** A building or any portion of a building in which repairs are made to motor vehicles including structural repair, rebuilding or reconditioning of motor vehicles, or parts thereof, including collision service; spray painting; body fender, clutch, transmission, differential, axle, spring, and frame repairs; major overhauling or engines requiring the removal of the engine cylinder, head or crankcase pan; repairs to radiators requiring the removal thereof; complete recapping or retreading of tires; or similar activities. See also “Automotive Service Station”.
 - 201. **WAITING SPACE:** An unenclosed area outside the public right-of-way that accommodates customers in vehicles being served or waiting to be served at a drive-thru facility, car wash, gasoline station, or other similar use. Also known as a stacking space.
 - 202. **WALKWAY:** A public way for pedestrian use only, which may or may not be located along the side of a road.
 - 203. **WASTE WATER TREATMENT PLANT (WWTP):** A facility at the end of a sanitary collection system that processes the influent waste and discharges water to a receiving stream, treated to the standards of the Ohio EPA. (Effective 5/28/09)
 - 204. **WATERCOURSE:** Any brook, channel, creek, river, or stream having banks, a defined bed, and definite direction of either continuous or intermittent flow. (Effective 5/28/09)
 - 205. **WATERCOURSE, DESIGNATED:** A watercourse within Montville Township that is in conformity with the criteria set forth in these regulations. (Effective 5/28/09)
 - 206. **WETLAND:** Those areas that are inundated or saturated by surface or ground water at a frequency and duration sufficient to support, and under normal circumstances do support, a prevalence of vegetation typically adapted for life in saturated soil conditions, including swamps, marshes, bogs, wet meadows, sloughs, potholes, river overflows, mud flats, natural ponds, and similar areas and/or as shown on the Official Wetlands and Watercourse map(s), or any land area meeting the criteria established under

Section 404 of the Federal Clean Water Act or subsequent federal or state legislation which restricts filling and/or dredging to such an extent that the use of the land for the construction of residential and/or commercial structures is effectively prohibited. (Revised 5/28/09)

- 207. WETLANDS, CATEGORY 1: A low quality wetlands classification as defined in Ohio Administrative Code (OAC) Rule 3745-1-54(C) of the Ohio EPA. (Effective 5/28/09)
- 208. WETLANDS, CATEGORY 2: A medium quality wetlands classification as defined in Ohio Administrative Code (OAC) Rule 3745-1-54(C) of the Ohio EPA. (Effective 5/28/09)
- 209. WETLANDS, CATEGORY 3: A high quality wetlands classification as defined in Ohio Administrative Code (OAC) Rule 3745-1-54(C) of the Ohio EPA. (Effective 5/28/09)
- 210. WIRELESS TELECOMMUNICATIONS ANTENNA OR “ANTENNA”: The physical device through which electromagnetic wireless communications signal authorized by the Federal Communications Commission is transmitted or received. Antennas used by amateur radio operators are not included in this definition. (Effective 5/28/09)
- 211. WIRELESS TELECOMMUNICATIONS FACILITY: A facility consisting of the equipment and structures involved in receiving telecommunications or radio signals from a mobile radio communications source and transmitting those signals to a central switching computer which connects the mobile unit with the land-based telephone lines. (Effective 5/28/09)
- 212. WIRELESS TELECOMMUNICATIONS TOWER: A structure intended to support equipment used to transmit and/or receive telecommunications signals including monopoles, guyed and lattice construction steel structures. (Effective 5/28/09)
- 213. YARD: An open space on the same lot with a principal building, extending between the lot line and the extreme front, rear or side wall of the principal building.
 - a) YARD, FRONT: The area extending across the full width of the lot between the front of the principal building or proposed principal building and the front lot line. Where a lot is located at the intersection of two or more streets, there shall be a front yard on each street side of a corner lot. A double frontage or through lots shall have a front yard on both streets. Where the

public right-of-way line is not established, the right-of-way shall be assumed to be 30 feet on either side of the centerline of the road. Where a major or collector thoroughfare is designated on the Land Use and Thoroughfare Plan, the front yard depth shall be measured from the proposed street right-of-way line.

b) YARD, REAR: The area extending across the full width of the lot between the rear of the principal building or the proposed principal building and the rear lot line. On corner lots, the rear lot line shall be considered as parallel to the street upon which the lot has its least dimension. On both corner lots and interior lots, the rear yard shall be in all cases at the opposite end of the lot from the front yard.

c) YARD, SIDE: The area between the main building and the side lot line extending from the front wall to the rear wall of the principal building.

214. YARD, REQUIRED. (See also Setback Line): The open space between a lot line and a setback line for a building, parking area or use that is the minimum area required to comply with the regulations of the district in which the lot is located, and within which no structure shall be located except as expressly permitted in this Zoning Resolution.

215. ZONING MAP: The “Zoning Districts Map of Montville Township, Medina County, Ohio.”

216. ZONING INSPECTOR: The individual designated to administer the Montville Township Zoning Resolution. Duties of the Zoning Inspector may also be performed by a designated agent.

Figure 6
Driveway Details

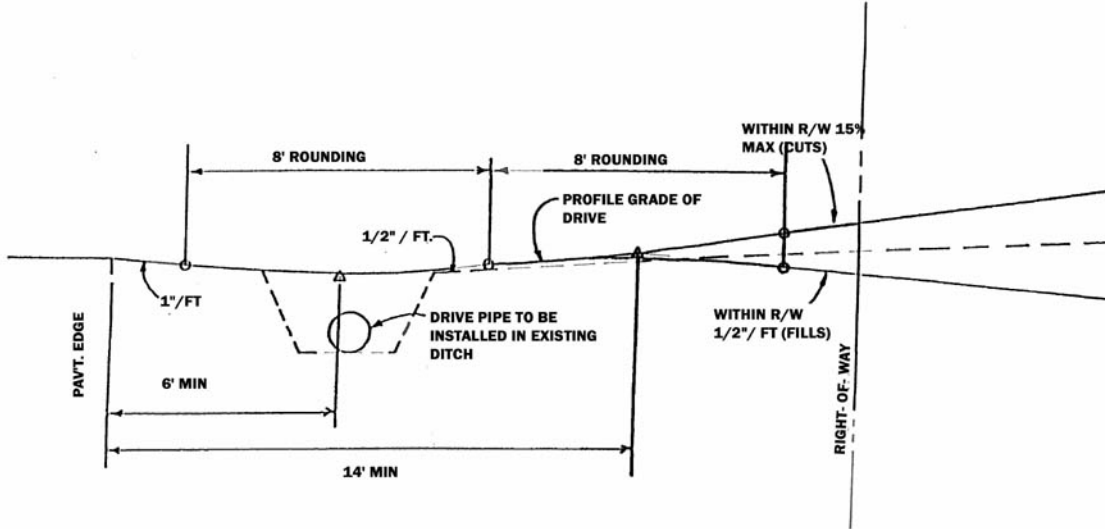

NORMAL DRIVEWAY PROFILE FOR ORIGINAL MEDINA COUNTY RURAL TYPE ROADS WITH OPEN DITCH

MEDINA COUNTY ENGINEER DRIVEWAY DETAILS	
DW-2	
DRAWN BY R. Rubrich	APPROVED _____
DATE 7-18-80	REVISED _____

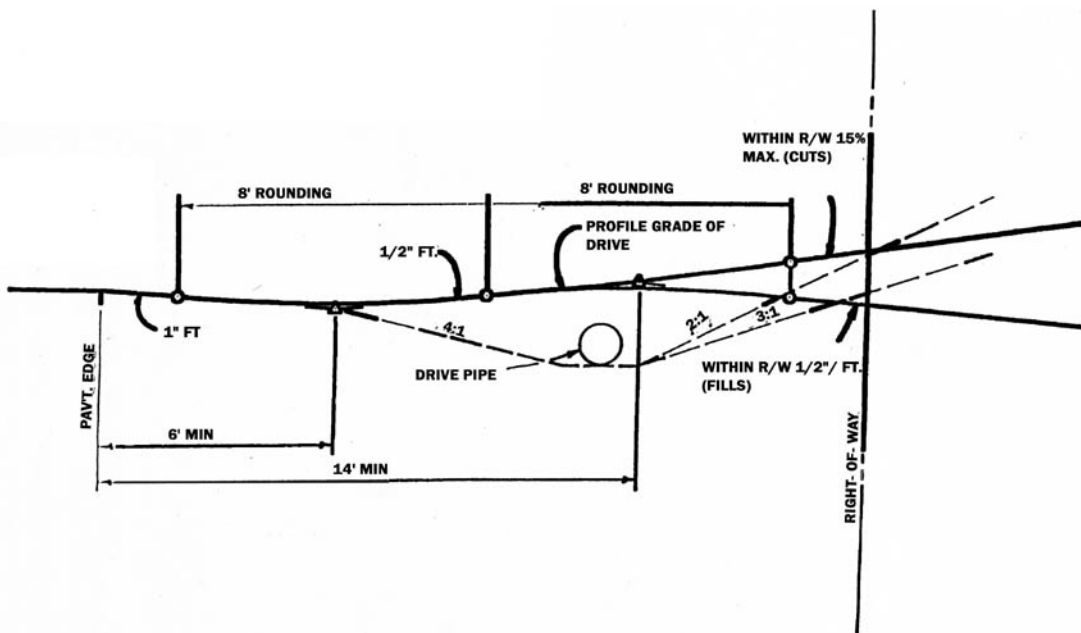

NORMAL DRIVEWAY PROFILE FOR RURAL TYPE RESIDENTIAL AND COLLECTOR ROADS WITH OPEN DITCH

MEDINA COUNTY ENGINEER DRIVEWAY DETAILS	
DW-4	
DRAWN BY R. Rubrich	APPROVED _____
DATE 7-18-80	REVISED _____